



COMMERCIAL DOOR OPERATOR

Maximum Door Area (Sq. Ft.)

HORSEPOWER	ROLLING					
	24 GA. STEEL	22 GA. STEEL	20 GA. STEEL	20 GA./18 GA. STEEL	16 GA. STEEL	16 GA. STEEL
	ALUMINUM DOORS	ALUMINUM DOORS	ALUMINUM DOORS	STEEL GRILLES	ALUMINUM DOORS	ALUMINUM DOORS
	24 GA./22 GA. STEEL		20 GA. STEEL	20 GA. STEEL	16 GA. STEEL	16 GA. STEEL
	FIBERGLASS	ALUMINUM DOORS	WOOD DOORS	ALUMINUM DOORS	ALUMINUM DOORS	ALUMINUM DOORS
			24 GA. STEEL INSULATED	20 GA. STEEL INSULATED	16 GA. STEEL INSULATED	16 GA. STEEL INSULATED
1/3	310	285	260	210	175	125
1/2	400	350	320	280	250	200
3/4	560	500	450	380	325	275
1	640	625	560	475	400	310

NOTE: On steel insulated doors, a 24-gauge back panel is assumed. If a heavier back panel is supplied, use the next higher HP rating.

Standard Features

- Motor**
 Continuous-duty high-starting torque motor with instant reverse and overload protection. Available in 1/3, 1/2, 3/4 and 1 HP; single- or three-phase. Capacitor start on single-phase. Removable without affecting limit switch settings.
- Emergency Manual Operation**
 Model H provides easy emergency manual operation using an electrically interlocked floor level disconnect and chain hoist mechanism.
- Wiring Type(L3)**
 C2 (factory default), B2, D1 and E2 wiring types are available. Failsafe (T, TS and FSTS) wiring can be selected with the addition of a CPS-L, CPS-LN4 or failsafe edge and CPS3 card.
- Control Circuit**
 5V DC NEC Class 2 (logic), 24V DC NEC Class 2 (mechanical).
- Drive Reduction**
 First-stage heavy-duty 5L V-belt; second and third stages #48 chain; #50 drive chain.
- PosiLock® Mechanical Brake System**
 Self-locking mechanical reduction system functions as a holding brake.
- Bearings**
 Industrial ball bearings on a 1" output shaft; heavy-duty, oil-filled iron bearings on reduction shafts.
- Friction Clutch**
 Adjustable friction clutch helps protect against major damage to door and operator should the door meet an obstruction.
- Push Button Station**
 3-button station for open/close/stop functions is standard for all operators. Controls with 1, 2 and 3 buttons are available.
- Radio Receiver & External Radio Control Terminal**
 315MHz radio receiver included as standard on Logic 3.0. Accepts up to 23 Security+® remote controls or unlimited DIP switch remotes. External terminals provide quick, convenient connections for retrofitting or adding radio controls on logic or mechanical operators.
- Construction**
 NEMA 1 type electrical box, heavy-duty 11-gauge steel frame with durable powdercoat finish, all reduction sprockets drilled and pinned to shafts.

Value Added Standard Features

- Timer-to-Close**
 Automatically closes the door - programmable in 5-second or 1-minute increments. Part of the CPS-L, CPS and CPS-LN4 photo-eye packages or in the Logic 3.0 plug-in card package.

CHAMBERLAIN®

LiftMaster®

THE CHAMBERLAIN GROUP, INC.
845 Larch Avenue • Elmhurst, IL 60126

www.liftmaster.com • http://specs.chamberlain.com/architectscorner

- Maximum Run Timer**
 Signals door to reverse or stop if closing time exceeds maximum by more than 10 seconds.
- Mid-Stop**
 Stops door at programmable mid-stop during open travel.
- Delay-on-Reverse Circuit**
 A 1.5 second delay-on-reverse circuit to prevent premature door and operator wear.

Control Accessories and Options

- CPS® Commercial Protector System®:**
 CPS(M), CPS-N4(M), CPS-L(L3), CPS-LN4(L3) (recommended)
 "Non-contact" photo safety sensor designed to sense an obstruction and signal the door operator to reverse to open.
 - Sensing Edge (recommended)**
 Senses an obstruction and signals door operator to stop or reverse upon contact. An electric or pneumatic sensing device can be added to bottom edge of door. Requires D1, C2 or B2 wiring.
 - Brake**
 Heavy-duty solenoid-actuated brake.
 - Transmitters**
 1- and 3-button transmitters available for Logic 3.0. 3-button transmitter can be programmed for open/close/stop functionality. Radio receiver and transmitters available for mechanical operators.
 - Rolling Door Interlock Switch**
 Interlock switch disables the operator control circuit when a manual door lock is engaged, preventing damage to the door and operator.
- ### Available Plug-in Options for the Logic 3.0 Control Board (L3)
- Auxiliary Contact Board**
 Used to operate security, warning, heating or other 5V to 240V devices. Features both normally open and closed contacts that actuate in conjunction with limit switches.
 - Red/Green Warning Light**
 Provides safety warning prior to close (when using timer-to-close feature).
 - CPS3 Option**
 Enables the addition of a second set of photo-eyes or 2- or 4-wire, self-monitoring edge.

Available Mechanical Reversing Contactor Circuit (M)

Industrial linear contactor provides significantly longer control runs than conventional contactors. Circuit provides easy selection between C2 and B2 wiring with the movement of a single wire.

Technical Information

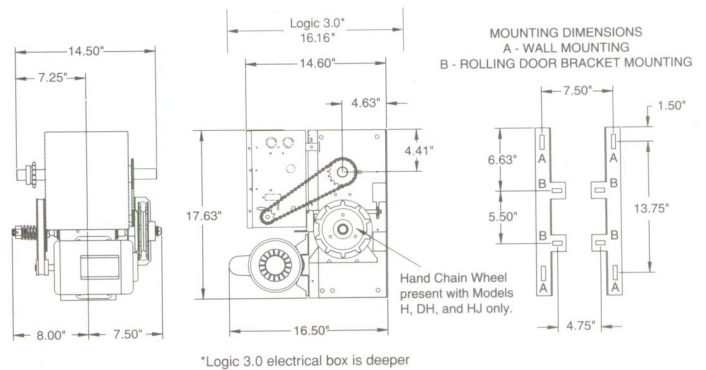

مركز المعادن
 (للخدمات والبيع)
 تليفون ٩٦٥ | ٤٧٤٨٩٠٣ فاكس ٩٦٥ | ٤٧٤٨٩٠٣
 INDS.
METAL CENTER co.
 Tel. 965 | 4748903 - Fax 965 | 4748909 W.C.C.



Chamberlain reserves the right to make design or specification changes without notice.
©2008 The Chamberlain Group, Inc. Printed in U.S.A. 6/08 LMCDOOH

Industrial-Duty Hoist Operator

COMMERCIAL DOOR OPERATOR

H

MODEL

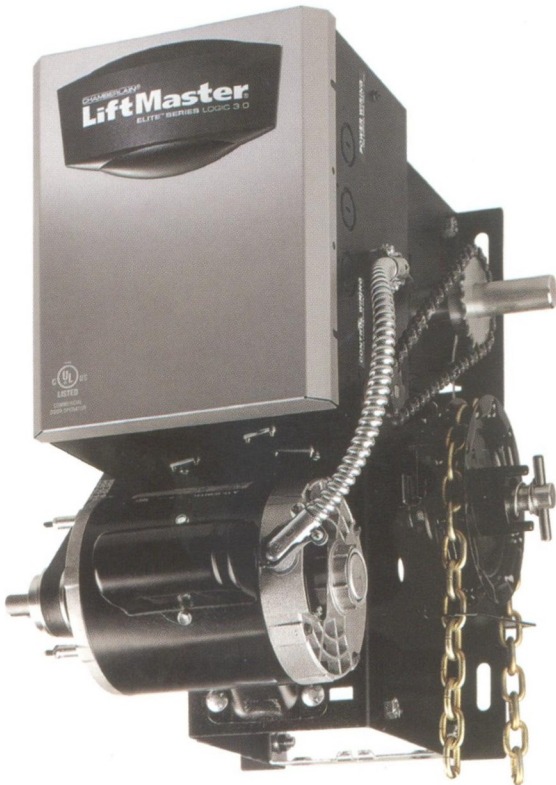

Logic 3.0 Technology

Elite Series™ Commercial Door Operators are engineered, manufactured and tested to provide reliable service to meet the toughest commercial applications.

Added Value

- Built-in 3-channel, 315MHz radio receiver accepts up to 23 Security+® or unlimited DIP switch remote controls.
- All LiftMaster® 3-button remotes can be programmed for open/close/stop operation.
- Maintenance Alert System™ lets you establish a routine maintenance schedule based on the number of cycles and/or calendar date. Includes self-diagnostic system for easy troubleshooting.
- Timer-to-close may be set to close in 5-second or 1-minute increments.
- Thermal motor overload can be reset from the 3-button control station.
- Built-in programmable mid-stop.
- Built-in programmable maximum run timer.

Reliability

- Switchless motor eliminates stuck start switch and motor malfunctions on single-phase operators.
- All high-voltage connections have been removed from the board for safer installation and improved reliability.
- 1-1/2 second delay-on-reverse helps prevent door and operator wear.

Programming Simplicity

- Selector dial replaces DIP switches for selecting wiring types and programming, including failsafe and non-failsafe wiring.
- Diagnostic LEDs speed installation and troubleshooting.
- Motor direction jumper lets you change motor direction by simply moving a jumper.

- Continuous-duty high-starting torque motor
- Universal-mount frame design
- Industrial ball bearings on output shaft
- Emergency chain hoist with electric interlock
- 115V, 208/230V, 460V, 575V, 24V NEC Class 2 Circuit with 40VA transformer

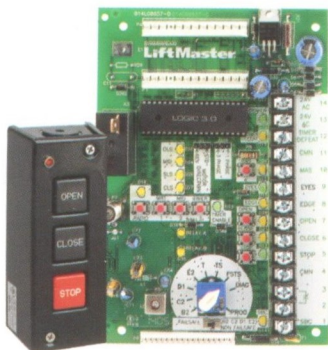

Includes the Logic 3.0 board and the exclusive Maintenance Alert System™

CHAMBERLAIN®

LiftMaster

ELITE SERIES™ LOGIC 3.0